

CONDIZIONATORI DA PARETE INDOOR UL LISTED UL LISTED WALL MOUNTED INDOOR COOLERS

800W
800W



Descrizione Description

• Tutte le versioni bifase e trifase possono essere alimentate a differenti tensioni, mediante la modifica del cablaggio interno (seguire schemi).

■ Campo regolazione temperatura (set di fabbrica) da / a: **+30°C / +40°C**

■ Livello di rumore **67 dB (A)**

■ Tipo di refrigerante **R513a**.

■ Tipo ciclo di lavoro **100%**

■ NEMA TYPE 12

Opzionale

COLORE SPECIALE = R9ULK...

• All two-phase and three-phase versions can be supplied with different voltages, by changing the internal wiring (follow diagrams).

■ Temperature regulating range (factory set) from /to **+30°C / +40°C**

■ Noise level **67 dB (A)**

■ Coolant type: **R513a**.

■ Operating cycle type **100%**

■ NEMA TYPE 12

Optional

SPECIAL COLOR = R9ULK...

IP54

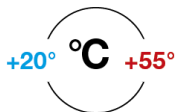

Dati Tecnici Technical Data

COVER VERNICIATA/PAINTED

CODICE CODE	TENSIONE ALIMENTAZIONE POWER SUPPLY	FREQUENZA FREQUENCY HZ	POTENZA FRIGORIFERA (DIN_3168,W) REFRIGERATING POWER (DIN_3168,W)		DISPOSITIVO DI PROTEZIONE E SICUREZZA SUGGERITO SUGGESTED PROTECTION AND SAFETY DEVICE	POTENZA ASSORBITA POWER CONSUMPTION		FLA MASSIMA CORRENTE DI ESERCIZIO FLA MAXIMUM OPERATING CURRENT	CORRENTE DI SPUNTO STARTING CURRENT	PESO WEIGHT KG
			L35/L35	L35/L50		L35/L35	L35/L50			
R5ULK08011L	115 Vac - 1 ph	50/60	830 / 900	650 / 690	12 A	420/480	470/560	6 / 6,5 A	34 A	28
R5ULK08021L	230 Vac - 1 ph	50/60	830 / 900	650 / 690	6 A	420/480	450/540	3 / 3,3 A	17 A	28
R5ULK08042L	460 Vac - 2 ph	50/60	830 / 900	650 / 690	9 A	420/480	450/540	1,5 / 1,7 A	9 A	31

COVER INOX/AISI 304

CODICE CODE	TENSIONE ALIMENTAZIONE POWER SUPPLY	FREQUENZA FREQUENCY HZ	POTENZA FRIGORIFERA (DIN_3168,W) REFRIGERATING POWER (DIN_3168,W)		DISPOSITIVO DI PROTEZIONE E SICUREZZA SUGGERITO SUGGESTED PROTECTION AND SAFETY DEVICE	POTENZA ASSORBITA POWER CONSUMPTION		FLA MASSIMA CORRENTE DI ESERCIZIO FLA MAXIMUM OPERATING CURRENT	CORRENTE DI SPUNTO STARTING CURRENT	PESO WEIGHT KG
			L35/L35	L35/L50		L35/L35	L35/L50			
RIULK08011L	115 Vac - 1 ph	50/60	830 / 900	650 / 690	12 A	420/480	470/560	6 / 6,5 A	34 A	28
RIULK08021L	230 Vac - 1 ph	50/60	830 / 900	650 / 690	6 A	420/480	450/540	3 / 3,3 A	17 A	28
RIULK08042L	460 Vac - 2 ph	50/60	830 / 900	650 / 690	9 A	420/480	450/540	1,5 / 1,7 A	9 A	31

800W
800W

Specifiche tecniche Technical Specs

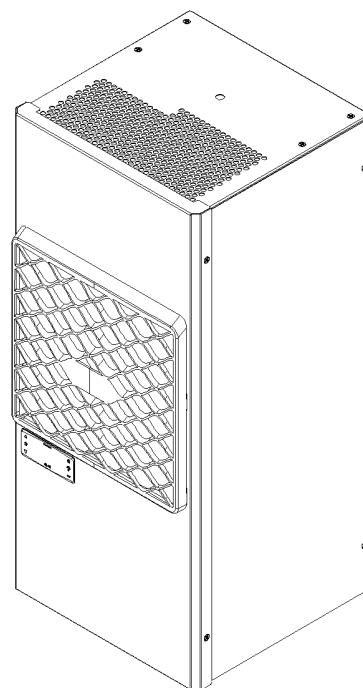
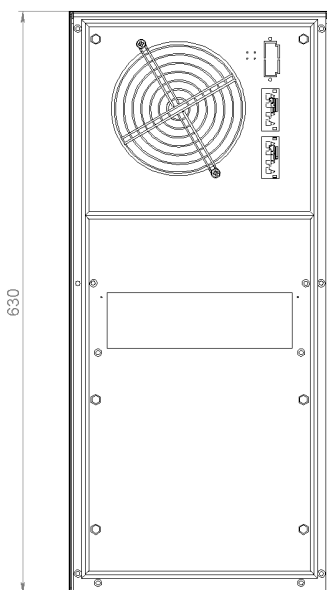
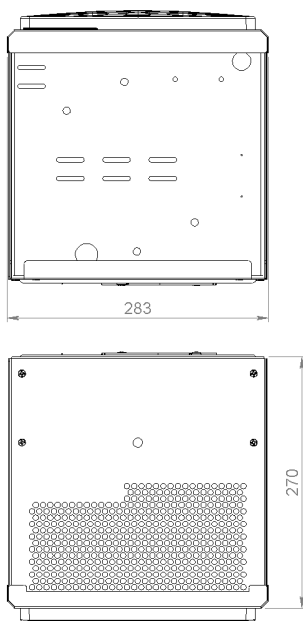

800W
800W

Specifiche tecniche Technical Specs

Potenza frigorifera
Refrigeration power

W 50Hz

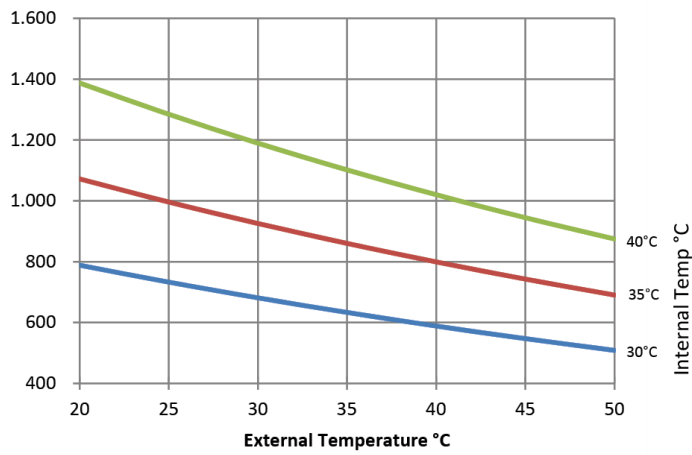

W 60Hz

